



TM

SmarTek Systems, Inc.

*14710 Kogan Drive
Woodbridge, VA 22193
703-680-6554
Sales 410-315-9727*

**Cabinet Watchdog
And
Voltage Monitor
Rev 2.0
User Guide**

22 January, 2004

Introduction

The Cabinet Watchdog (CWD) and Voltage Monitor is used to provide cabinet voltage measurements and watchdog services. The CDW can sample up to 4 different DC analog voltages (0 to 25.6 VDC). The sample rate for each channel is 10 samples per second and is averaged to 1 sample per second. The CWD can sample up to 2 optoisolated relay inputs (5 VDC to 24 VDC) and up to 6 TTL level inputs. The sample rate for the digital channels is 10 samples per second. The states of the digital inputs are accumulated for 1 second and the majority is used to determine the on or off state at a 1 sample per second rate. The CWD has 2 optoisolated relay outputs for driving external mechanical relays for controlling such things as cabinet power. The output relays are open collector, and can sink up to 30 milli-amps with a maximum collector voltage of 30 volts.

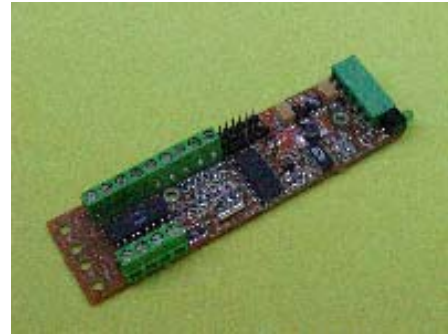

In Polled Mode, the CWD provides a watchdog function and expects to receive at least 1 polling request per 20 minutes. If the request is not received, the optoisolated relay output OC1 is activated (active low) for 12 seconds.

Setup and Connectors

The power and RS-232 signals are supplied via a 6 position connector designated as J6. The analog input channels are connected using the connector designated as J2, while the isolated relay inputs are connected using the connector designated as J4. The isolated output relays are provided at the connector designated as J5.

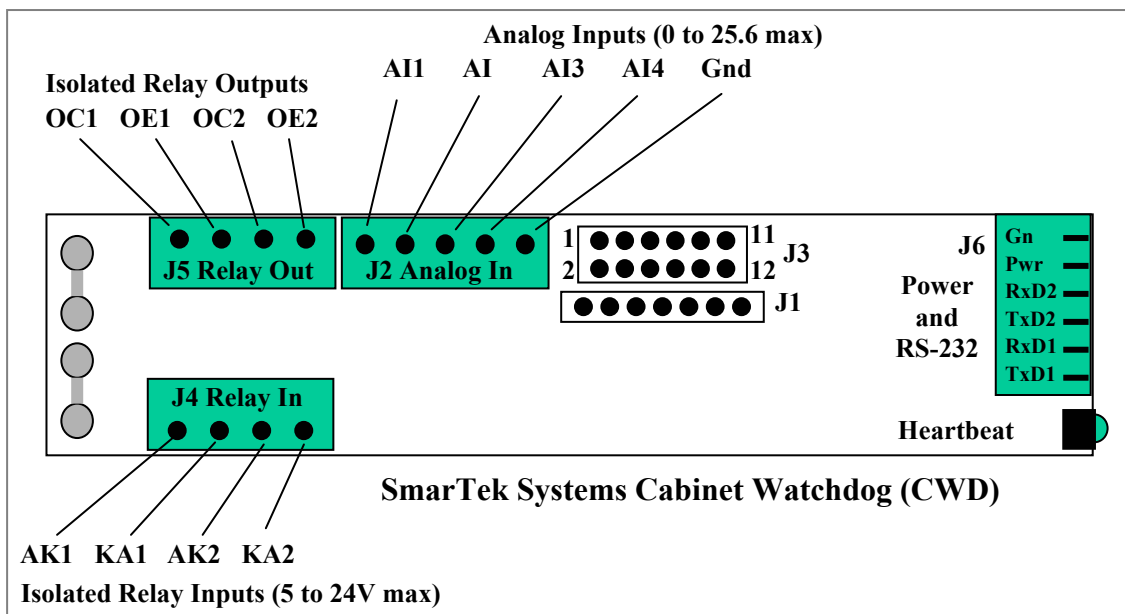

The CWD can report analog voltage measurements and the states of the digital inputs for a user selectable period or when polled via the RS-232 interface. The reporting period and the RS-232 baud rate is set by the user via push pin jumpers on the header designated as J3. Placing jumpers across pins 1-2 and 3-4 on J3 sets the baud rate as shown in the corresponding figure.

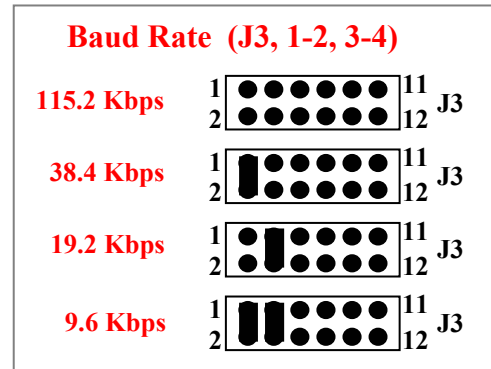

The reporting period is set using push pin jumpers across pins 5-6, 7-8, 9-10, and 11-12 on J3. The push pin locations for Polled Mode or Periodic Mode are shown in the corresponding diagram below. When operated in the Polled Mode, the CWD also functions as a watchdog and must be polled at least **once per 20 minutes** to keep the isolated output relay OC1 from activating as previously described.

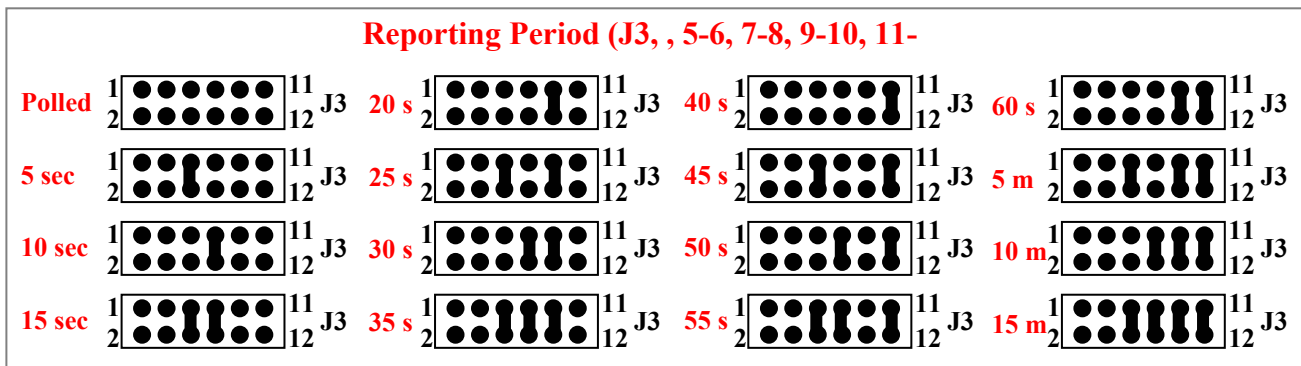

Polling Command and the CWD Message Format

When the CWD is operated in the Polled Mode, the message containing the measured voltages and the digital input states is obtained by sending the CWD the following command:

Command to CWD: POLL CWD

<ESC>{CWDxxxx,GDATA} <ESC> is ASCII character 27

CWD Response:

<2>CWDxxxx<sp>aa.aaa<sp>bb.bbb<sp>cc.ccc<sp>dd.ddd<sp>*ENABLED<CR><LF><3>
 or
 <2>CWDxxxx<sp>aa.aaa<sp>bb.bbb<sp>cc.ccc<sp>dd.ddd<sp>DISABLED<CR><LF><3>

CWDxxxx is the CWD ID (i.e. CWD0001, CWD0002, ect.)

<2> is the ASCII character 2 - the start of text character,

<3> is the ASCII character 3 - the end of text character,

<sp> is the ASCII character 32 - the space character,
 <CR> is the ASCII character 13 – the carriage return character,
 <LF> is the ASCII character 10 – the line feed character,
aa.aaa is the analog voltage measurement (volts) at pin AI1 on J2,
bb.bbb is the analog voltage measurement (volts) at pin AI2 on J2,
cc.ccc is the analog voltage measurement (volts) at pin AI3 on J2,
dd.ddd is the analog voltage measurement (volts) at pin AI4 on J2,

Connecting a Modem to Both CWD and SAS-CT (SAS-1)

Connecting the Cabinet Watchdog (CWD) and the SAS-1 (using a SAS-CT) to a modem is accomplished as shown in the diagram below. If the CWD only is connected to a modem or cabinet controller, then the RS-232 Signal lines, Ground, and Power are connected to pins Gnd, Pwr, RxD1, and TxD. If the modem needs the hardware flow control lines, then jumpers between pins 4 and 6 and between 7 and 8 are needed inside the DB-9 connector shell as shown. The modem should be setup to ignore DTR (typically used to “hang up” the modem) since there is no means of controlling the DTR line from either the CWD or the SAS-CT.

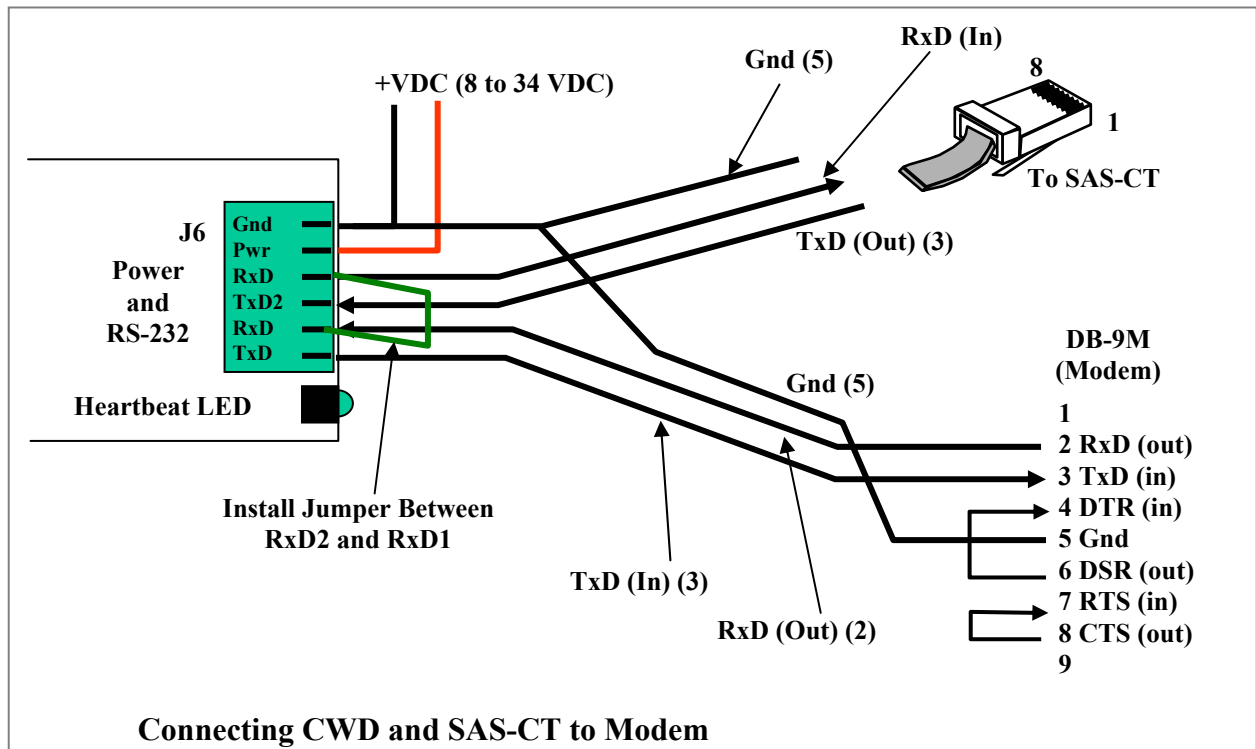

Additional CWD Commands

Command to CWD: RESET

<ESC>{CWDxxxx,RESET} CWDxxxx is current ID.

CWD Response:

Chr(2)OKChr(3) “OK” is ASCII.

Command to CWD: ENABLE Watchdog Function

<ESC>{CWDxxxx,WDE} CWDxxxx is current ID.

CWD Response:

Chr(2)OKChr(3) “OK” is ASCII.

Heartbeat Green LED period when CWD is ENABLED is 1.5 seconds.

Command to CWD: DISABLE Watchdog Function

<ESC>{CWDxxxx,WDD} CWDxxxx is current ID.

CWD Response:

Chr(2)OKChr(3) “OK” is ASCII.

CWDxxxx is Disabled Indefinitely

Heartbeat Green LED period when CWD is DISABLED is 0.5 seconds.

Command to CWD: Get CWD ID

<ESC>{CWD0000,GETID}

CWD Response:

Chr(2)CWDyyyyChr(3) CWDyyyy is the current CWD ID

Response is delayed according to the CWD ID (i.e. CWD0000 or CWD0001-No delay, CWD0002-0.4 second delay, CWD0003-0.8 second delay, etc.)

Command to CWD: Change CWD ID

<ESC>{CWDxxxx,CHGID=CWDyyyy}

CWDxxxx is current ID and CWDyyyy is new ID.

CWD Response:

Chr(2)OKChr(3) “OK” is ASCII.

Command to CWD: Turn ON CWD Optoisolated Relay

<ESC>{CWDxxxx,SWON=n,tt} CWDxxxx is current ID,

n=1 for Relay 1, n=2 for Relay 2, n=3 for both Relay 1 and Relay 2
tt=00 for indefinite ON time, tt=01 to 59 fo ON time from 1 to 59 minutes.

Note: Cabinet Watchdog function is always ENABLED before opto-isolated Relay 1 is turned on. Therefore, Relay 1 cannot remain on indefinitely.

CWD Response:

Chr(2)OKChr(3) “OK” is ASCII.

Command to CWD: Turn Off CWD Optoisolated Relay

<ESC>{CWDxxxx,SWOFF=n} CWDxxxx is current ID,

n=1 for Relay 1, n=2 for Relay 2, n=3 for both Relay 1 and Relay 2

CWD Response:

Chr(2)OKChr(3) “OK” is ASCII.