

SmarTek Acoustic Sensor Version 1 (SAS-1) Introduction And Background

Introduction and Background

SAS-1 System Architecture

Geometry Considerations for SAS-1 Placement and Mounting

SAS Monitor and Setup Software for Windows 98/ME/XP

SAS-1 Table Top Demonstration

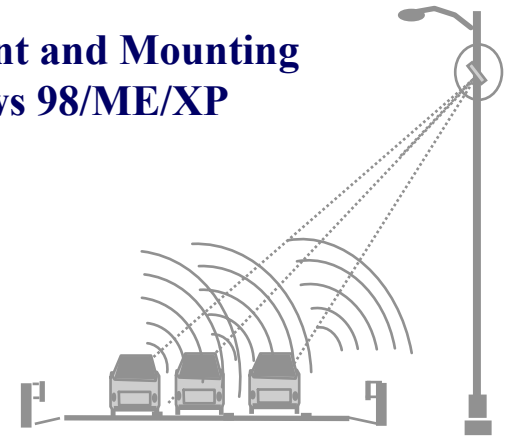

SmarTek Systems[®]

410-315-9727

gpieper@erols.com

www.smarteksys.com

SAS-1 Introduction and Background

- Passive Acoustic Sensor (Listen Only)
- “Side Fire” Mounting
- Calculates Acoustic Power All Directions All the Time
- Works at All Speeds (Free Flow to Stop and Go)

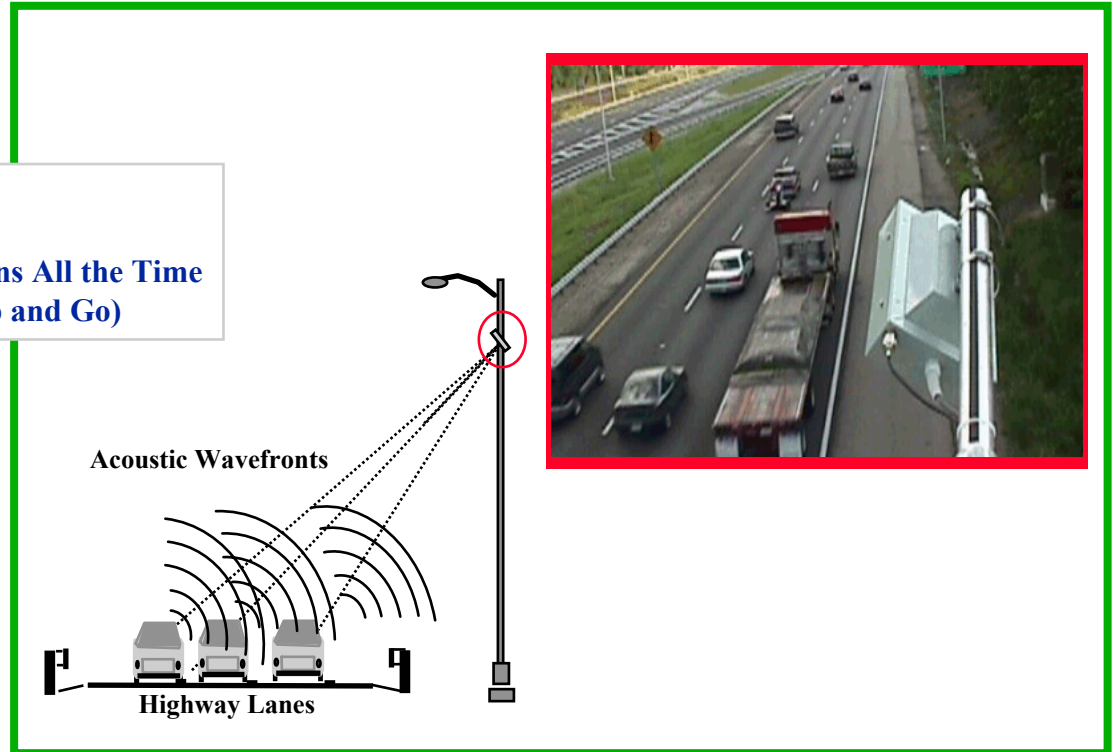
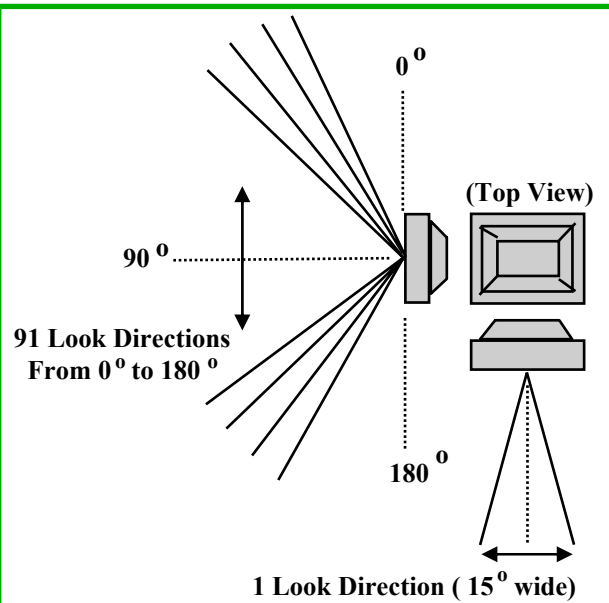

SmarTek Systems®

410-315-9727

gpieper@erols.com

www.smarteksys.com

SAS-1 Introduction and Background

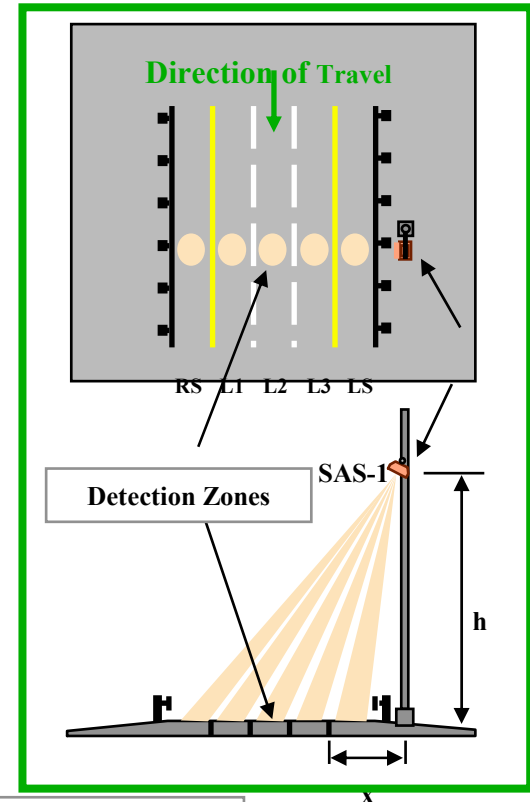
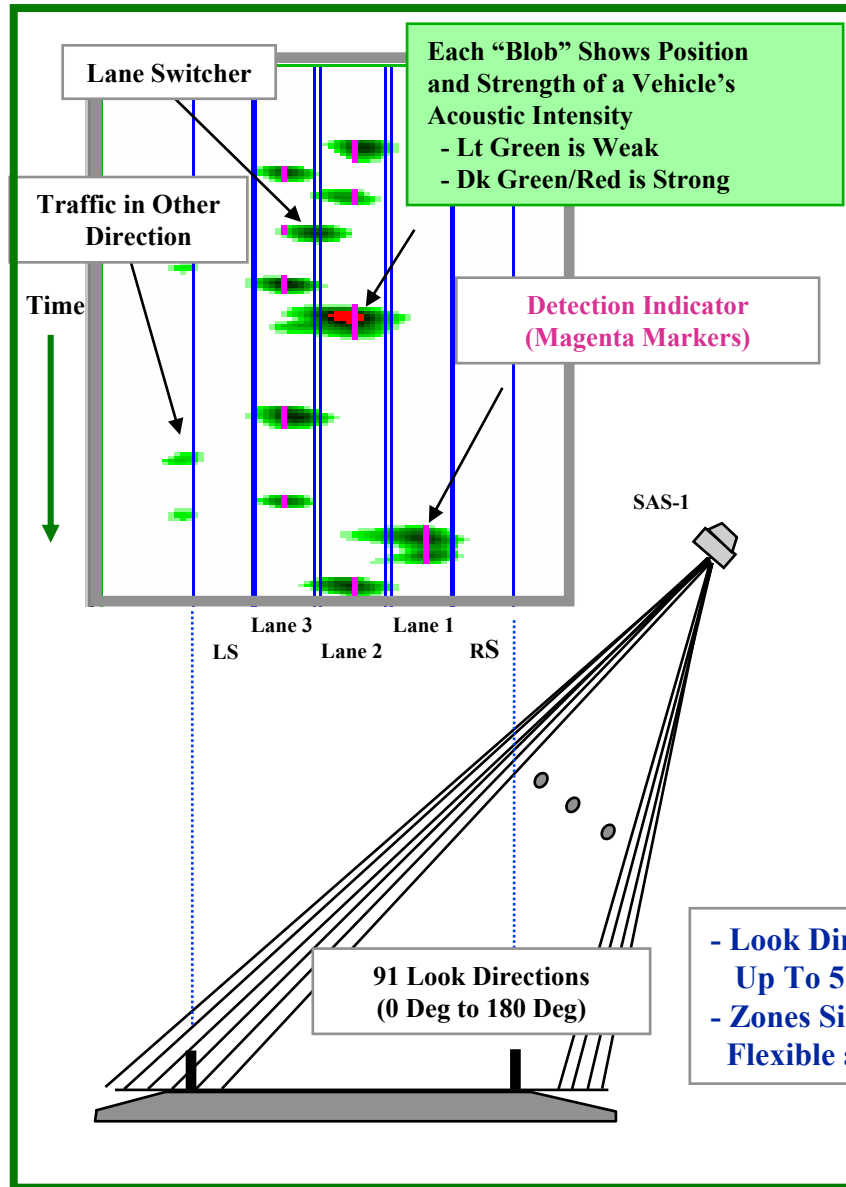

- Look Directions are Grouped to Form Up To 5 Detection Zones
- Zones Size and Position are Completely Flexible and are Selected During Setup



SmarTek Systems®

410-315-9727
 gpieper@erols.com
 www.smarteksys.com

SAS-1 Introduction and Background

SAS-1 Monitoring Modes

- **Multi-Lane Flow Mode**

The SAS-1 computes and reports vehicle count, lane occupancy and average speed for each lane (periodic or polled).

- **Multi-Lane Presence Relays**

The SAS-1 detects and indicates vehicle presence via a multi-lane relay message which is used by the SAS Relay Interface to synthesize real relay signals.

- **Multi-Lane “Dual Loop” Relays**

The SAS-1 detects and indicates vehicle presence emulating a “dual loop” speed trap configuration using a multi-lane relay message which is used by the SAS Relay Interface to synthesize real relay signals.

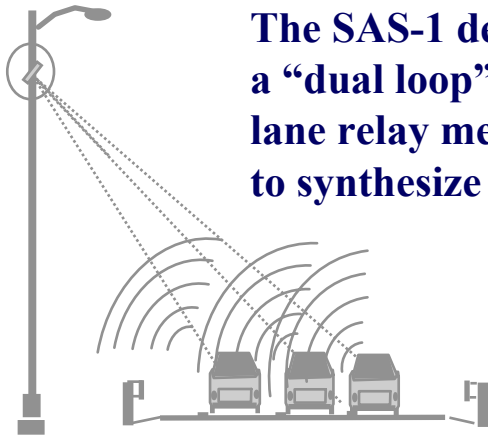

SmarTek Systems[®]

410-315-9727

gpieper@erols.com

www.smarteksys.com

Typical SAS-1 Architecture (Relay Interface)

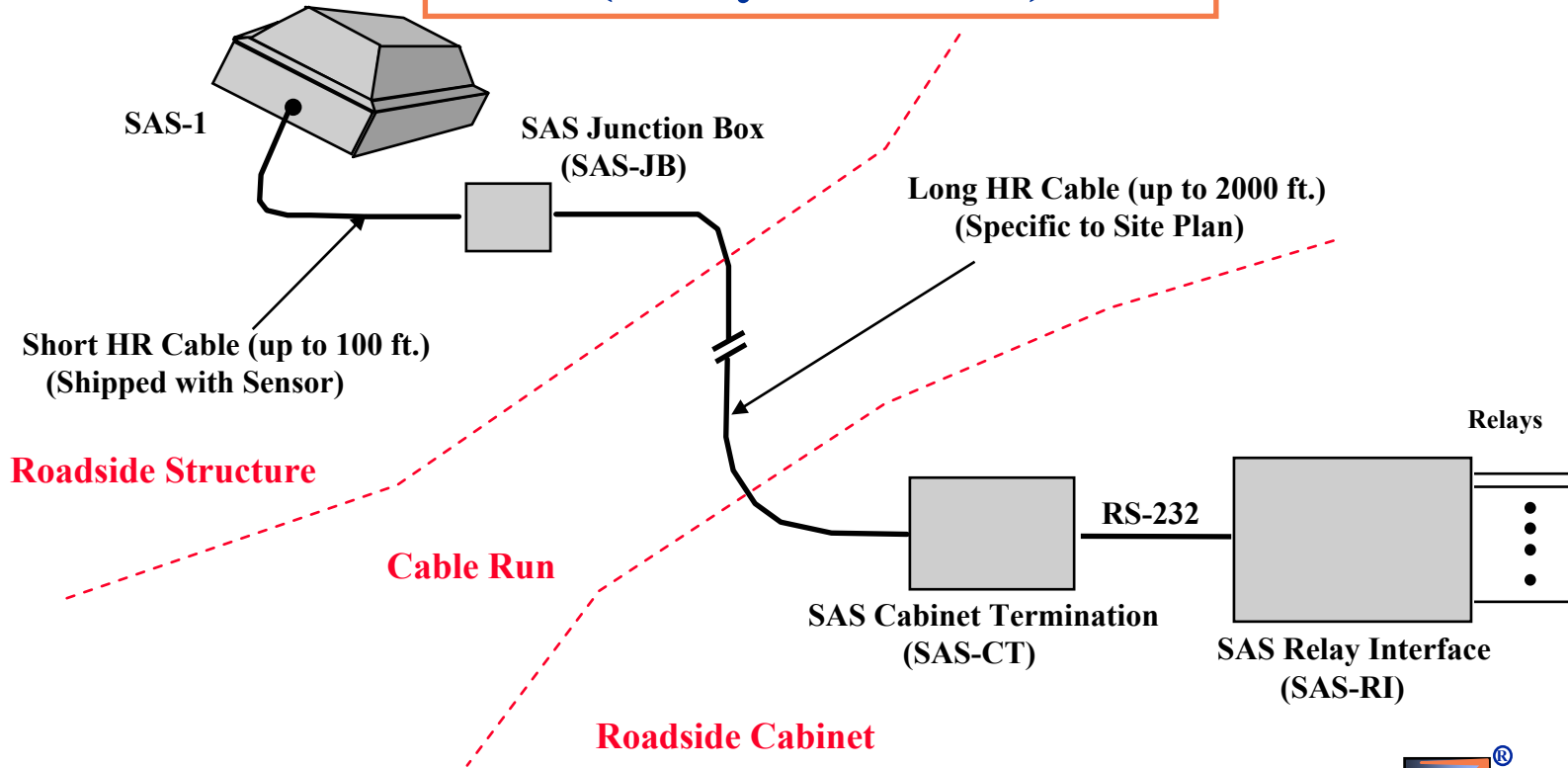

SmarTek Systems®

410-315-9727

gpieper@erols.com

www.smarteksys.com

SAS-1 Architecture

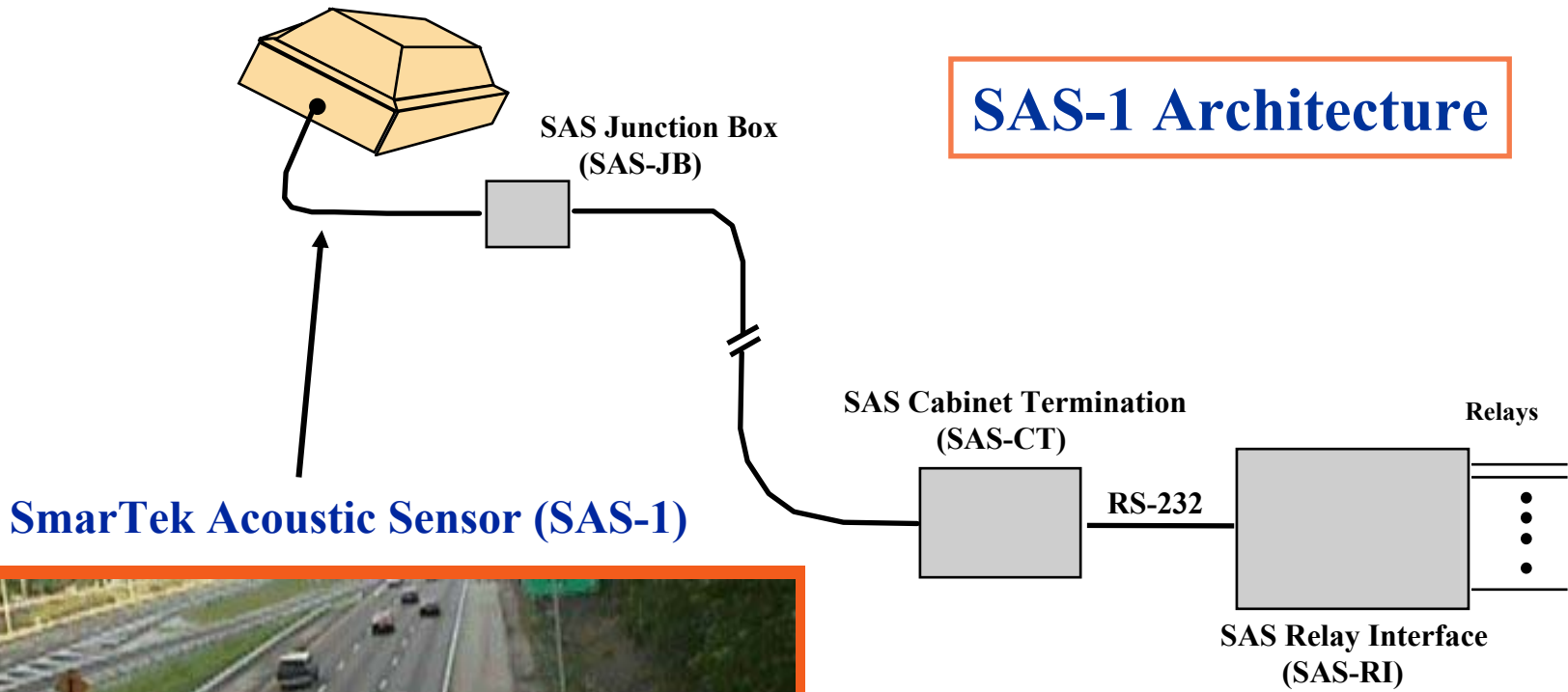

SmarTek Systems®

410-315-9727
gpieper@erols.com
www.smarteksys.com

SAS-1 Architecture

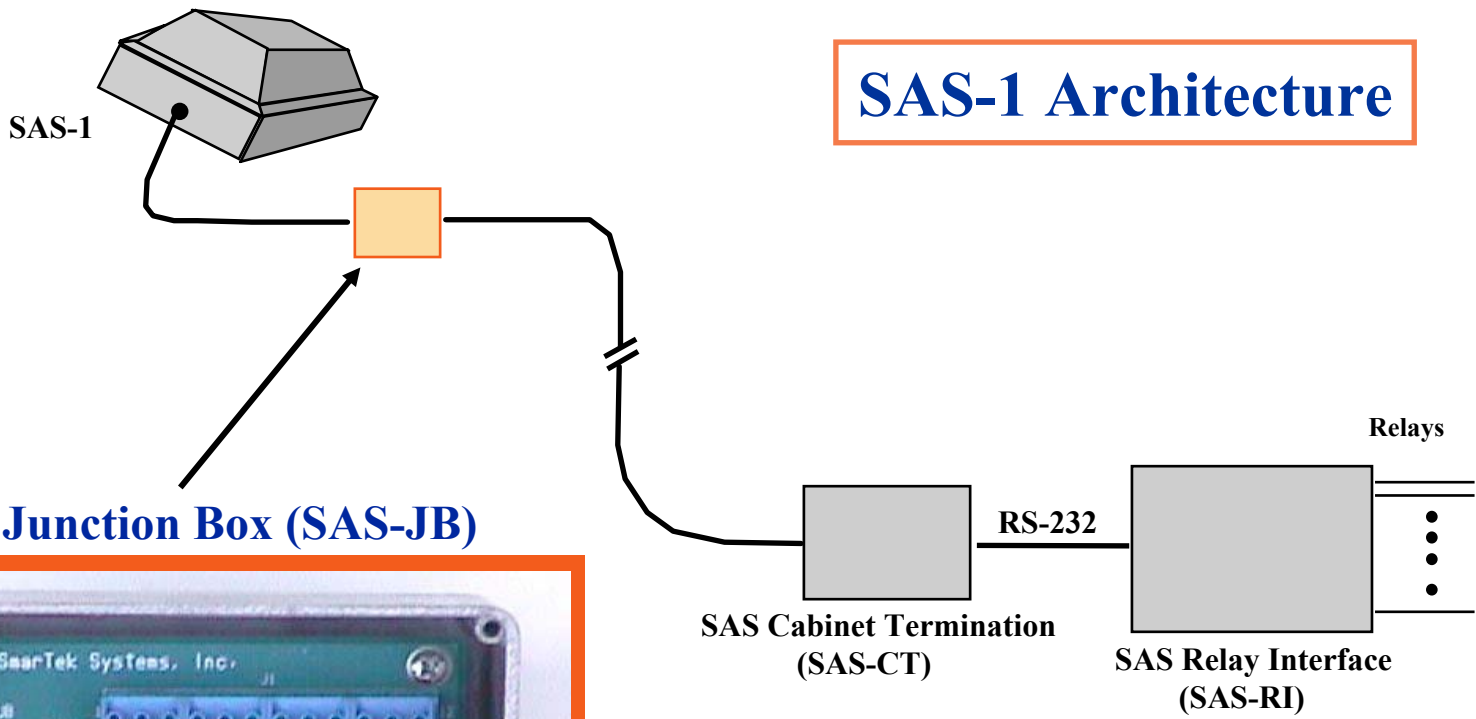

SAS Junction Box (SAS-JB)



SAS-1 Architecture

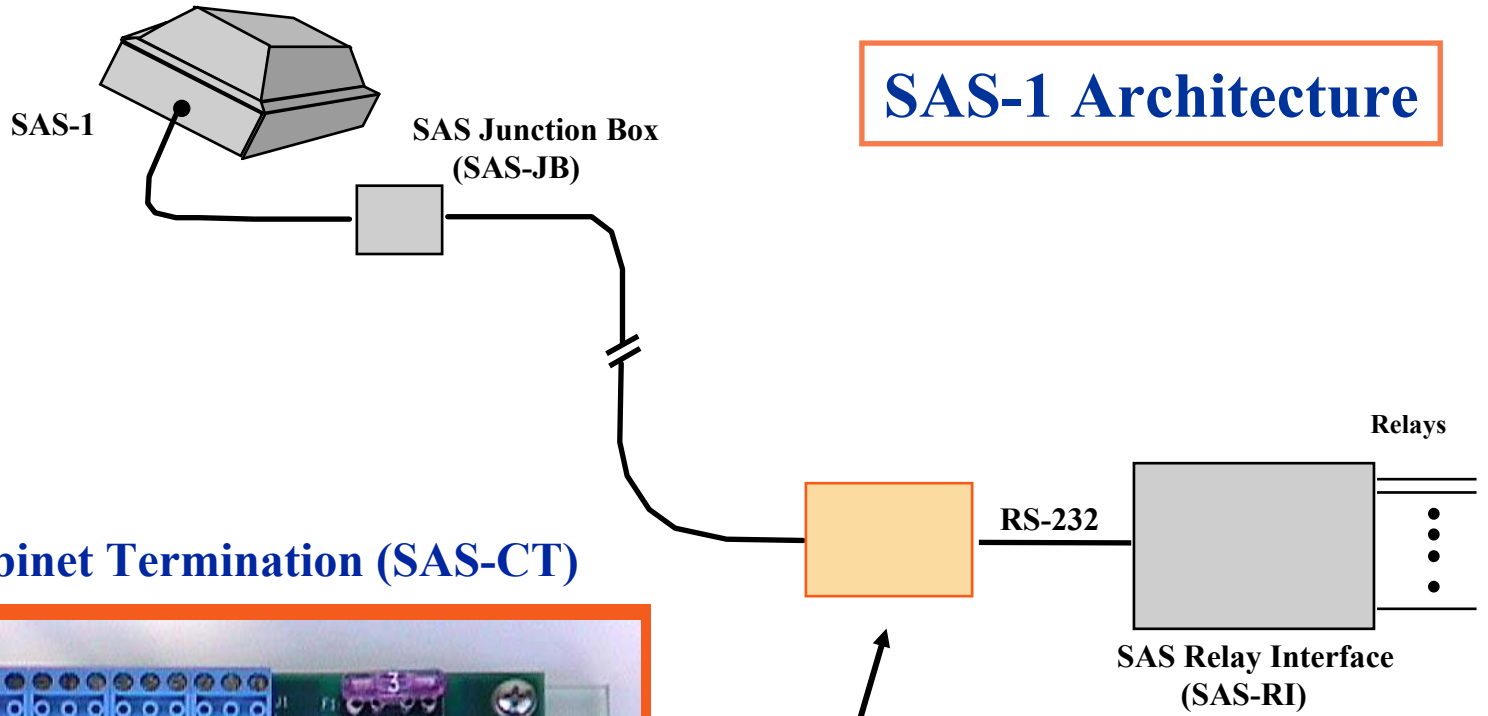

SAS Cabinet Termination (SAS-CT)

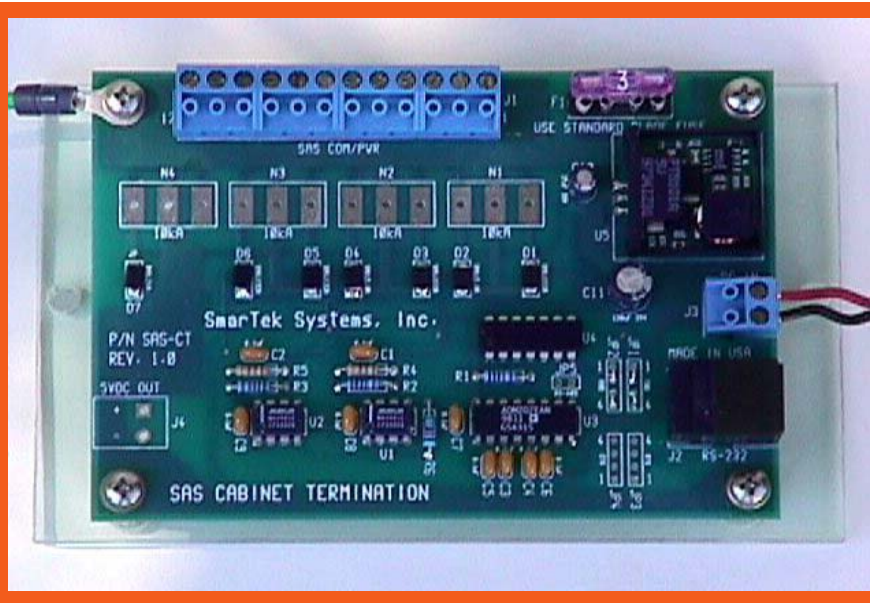

SmarTek Systems®

410-315-9727

gpieper@erols.com

www.smarteksys.com

SAS-1 Architecture

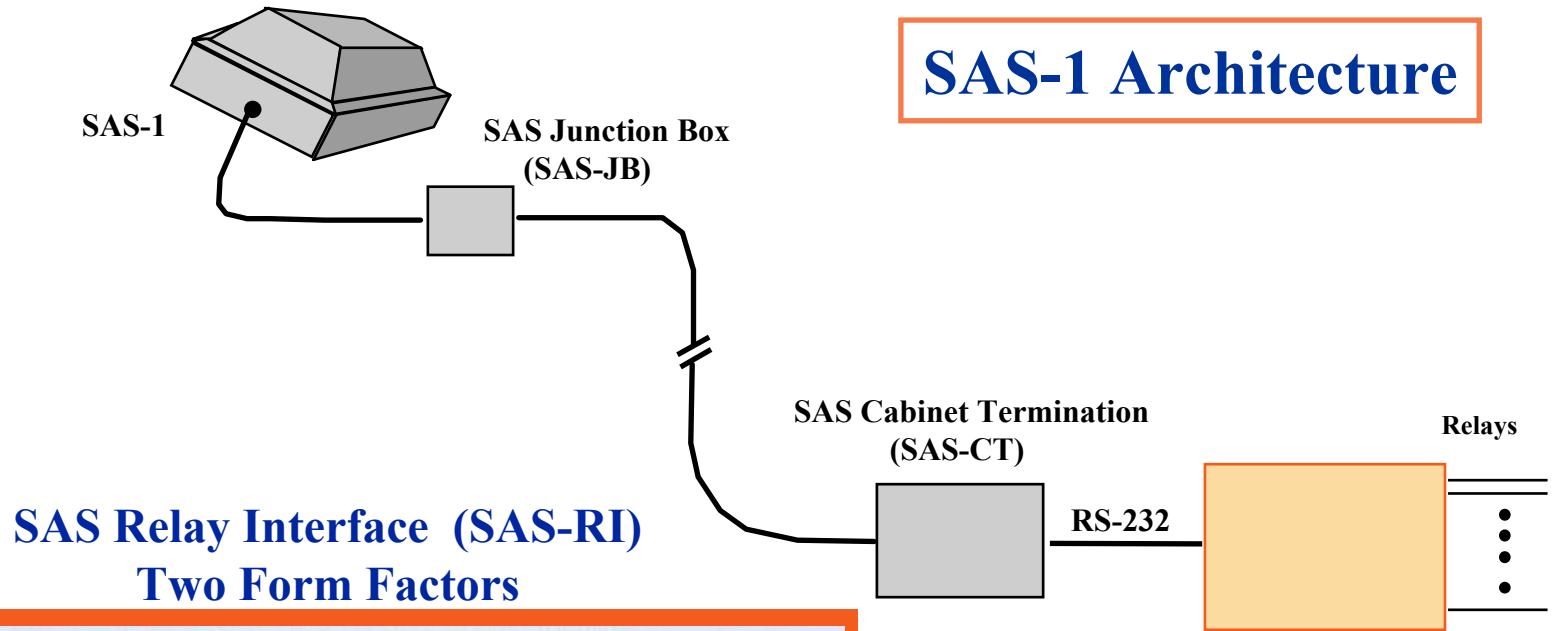

SAS Relay Interface (SAS-RI) Two Form Factors

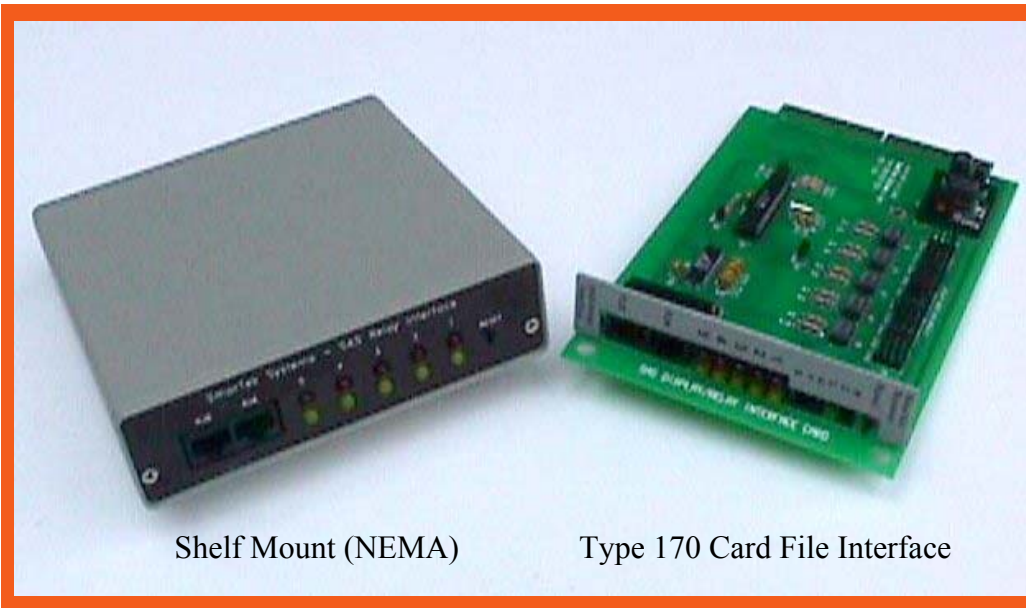

Shelf Mount (NEMA)

Type 170 Card File Interface



SmarTek Systems®

410-315-9727

gpieper@erols.com

www.smarteksys.com

Geometry Considerations for SAS-1 Placement

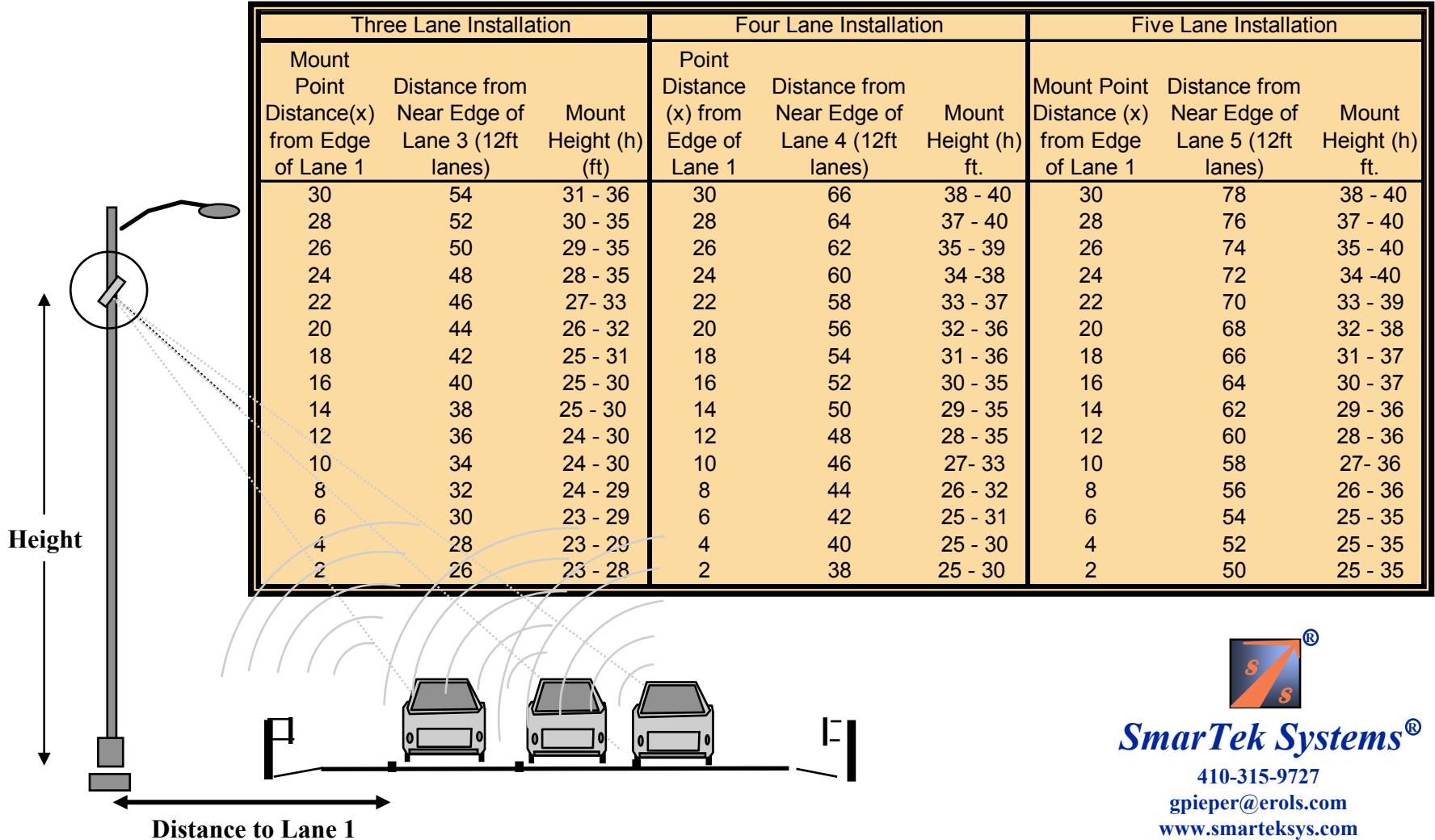

SmarTek Systems®

410-315-9727
 gpieper@erols.com
 www.smarteksys.com

SAS Monitor and Setup Software

Communication and Display

SAS-ID: SAS0001, Dspl Sens: 24.75, Scale: 0.45, Mode: 1

D-Mode: Flow, LFP: 1, P-Alpha: 0.10, Pwr Log: 2

Log: OFF

Detector

Max Det Sensitivity: 25.50, Rpt Intv: 30

Min Det Sensitivity: 22.00, Alpha: 0.12

Lanes or Zones

	5	4	3	2	1
Cntr	29	35	59	77	97
Size	3	7	11	15	15
Sens	10.00	10.00	10.00	10.00	10.00
AVL	10	10	10	10	10
Ocal	0.60	0.60	0.60	0.60	0.60
Cnt-All	0	1	1	3	0
Cnt-CT					
Cnt-TT					
Spd	2	68	50	55	55
OpSen	25.50	22.50	22.50	22.50	22.50
CalcSn	25.75	17.25	17.50	16.00	17.75

Buttons: Stop, Save Par, Save Image, Zones To Edge

Pixel= 2

Real Time TAI Mode Started... LF Update < 60 Sec

02/19/2001 9:42:52 PM

Menus

Display Parameters

Detection Parameters

Lane/Zone Parameters

Data Display Area

Start/Stop Button

Lane Finder Display



SmarTek Systems®

410-315-9727

gpieper@erols.com

www.smarteksys.com